

# Bottom Dump

## Car Unloader (BDCU)

### Models

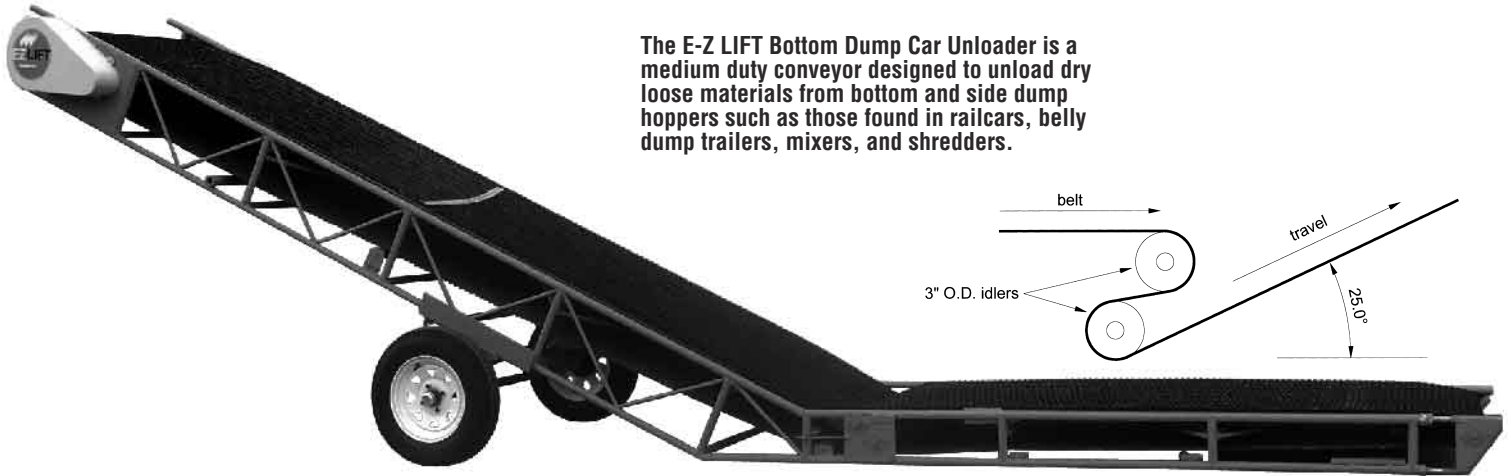

The E-Z LIFT Bottom Dump Car Unloader is a medium duty conveyor designed to unload dry loose materials from bottom and side dump hoppers such as those found in railcars, belly dump trailers, mixers, and shredders.

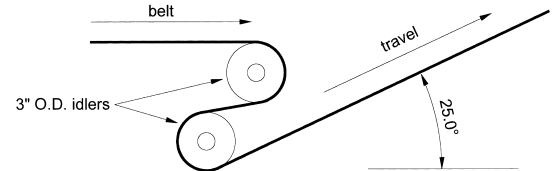

#### Belt—18" wide

Model	Approx. Wgt.*
82-18	400 lbs.

#### CAPACITIES

Lbs./Cu. Ft.	Tons/Hr.
30	36
50	60
75	90

#### Belt—24" wide

Model	Approx. Wgt.*
84-24	550 lbs.

#### CAPACITIES

Lbs./Cu. Ft.	Tons/Hr.
30	48
50	80
75	120

#### Belt—30" wide

Model	Approx. Wgt.*
86-30	700 lbs.

#### CAPACITIES

Lbs./Cu. Ft.	Tons/Hr.
30	60
50	100
75	150

#### Belt—36" wide

Model	Approx. Wgt.*
88-36	850 lbs.

#### CAPACITIES

Lbs./Cu. Ft.	Tons/Hr.
30	72
50	120
75	180

#### Typical uses include:

- Sand, aggregates, grains, chemicals, and numerous other powder, pellet, and bulk products

#### Features include:

- The belt turn from horizontal to incline is accomplished using two 3" O.D. full width idlers. One idler is set below the other but slightly off of vertical. The traveling horizontal belt first goes over the top idler and then threads down in a serpentine pattern between the two idlers. The same belt then proceeds up the incline. Material thrown off of the horizontal section is caught by the same belt now traveling at an incline (see sketch)
- Heavy duty 2 ply rubber mini cleated belt
- Combination slider bed with idler rollers
- High strength steel tubing truss frame
- 8 ft. long horizontal infeed section x 8" overall frame height
- 8 ft. long incline section fixed to discharge 40" high at a 25 degree incline
- Approximate 200 FPM belt speed
- Drive mounted overhead or side of discharge end
- **18" and 24" wide belts:**  
*2 hp 208-230/460V 3 phase TEFC unwired motor with internal V-belt and roller chain reduction, and safety guards*
- **30" and 36" wide belts:**  
*3 hp 208-230/460V 3 phase TEFC unwired motor with internal synchronized belt and roller chain reduction, and safety guards*
- Pneumatic tires and wheels to hold conveyor upright and for maneuverability
- Operating, maintenance, and safety instructions

#### Accessories:

- Start/Stop motor starter with enclosure

#### Options:

- Gas Engine
- Custom Lengths



#### Multilift, Inc.

2000 South Cherokee, Denver, Colorado 80223  
 Denver Area: 303.733.5533 FAX 303.733.5642  
 North American Toll Free: 1.800.821.9966

Specifications subject to change without notice  
 \*Weight w/o accessories